



ASSEMBLY INSTRUCTIONS

CLIP SHELVING SWING DOORS



ANGLE POST

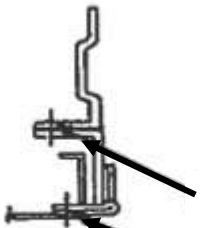

BEADED POST

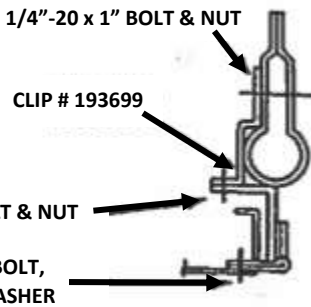

1. NOTE: RIGHT HAND DOOR IS PUNCHED FOR HANDLE.
BOLT DOORS TO EACH HINGE USING 2- #10-24 X 3/8" BOLTS, NUTS, & LOCKWASHERS.
SQUARE DOORS IN FRAME OPENING BEFORE TIGHTENING BOLTS.
2. BOLT DOOR & FRAME ASSEMBLY TO POST. USE 1/4"-20 X 5/8" BOLTS & NUTS FOR ANGLE POSTS (ONE BOLT & NUT PER EACH HINGE LOCATION).
FOR BEADED POSTS, ATTACH CLIPS TO POST USING 1/4"-20 X 1" BOLT & NUT (2 PER CLIP).
ATTACH DOOR AND FRAME ASSEMBLY TO CLIPS USING 1/4"-20 X 5/8" BOLTS & NUTS (2 PER CLIP).

LOCK ASSEMBLY DETAILS

1. MOUNT HANDLE ON DOOR WITH 2 MACHINE SCREWS.
2. INSERT LOCK BAR GUIDES INTO SLOTS ON TOP & BOTTOM OF DOOR. ENSURE GUIDES ARE LOCKED IN PLACE.
3. MOUNT LOCK BARS ON LATCH AS SHOWN.
4. ROTATE LATCH 90° CLOCKWISE (LOOKING INTO THE REAR FACE OF THE DOOR) AND HANDLE 90° COUNTER CLOCKWISE (LOOKING AT THE FRONT FACE OF THE DOOR) TO THE OPEN POSITION.
5. INSERT LOCK BARS INTO GUIDES WHILE ALIGNING SQUARE HOLE IN LATCH WITH SQUARE THREADED SHOULDER ON HANDLE.
6. APPLY JAM NUT.

